

## DATA SHEET, ELV1 ENCLOSURES

### CP Cases 19" Rack-mount Electronic Equipment Enclosures:

- Built to NEMA 4 or 4X construction standards (indoor/outdoor use, O.K. for contact with water)
- Materials: steel or stainless steel, Type 304 or 316 (aluminum also available)
- Height: standard "U" heights from 3U to 16U, custom sizes also available (overall enclosure height is typically 4" greater than U height)
- Width: 24" is standard external width
- Depth: different rack depths are available, including 19", 24", 29" and 34", custom depths also available (overall enclosure depth is typically 5" greater than rack rail depth)
- Mounting: enclosures are free-standing, with optional casters, leveling feet, forklift brackets and more
- Rack rails: enclosures include two pairs of vertical 19" rack-mount rails, both pairs horizontally-adjustable (front-to-rear) on welded uni-strut lengths
- Rack rails have clearance (not threaded) holes, for use with mounting fasteners (10-32 clip-nuts and 10-32 X 5/8" Phillips pan head machine screws, included)
- Doors: "dual access" design (single front door, single rear door), each fully gasketed, hinged left, latched right, with quarter-turn latches or 3-point locking latches
- Hinges: concealed, lift-off style (doors are removable, if desired)
- Grounding studs: included on each door and inside enclosure
- Print pocket: plastic construction, self-adhesive, shipped loose, for storing drawings, manuals, instructions and other documents
- Handles: heavy duty, stainless steel, black powder coated, typically four total (two per side)
- Casters (optional): 4" wheel, 5" overall height, four total, swivel style, two with brakes
- Finish, steel enclosures: commercial grade powder coating
- Finish, stainless steel enclosures: #4 brushed finish
- Standard colors: black, blue, desert tan, gray, olive drab, white (custom colors also available)
- Weights: enclosures generally range from 35 to 150+ lbs., depending on size (refer to size chart)
- Options (extensive list available): cable exit holes, drip shield, fan/filter, lifting eyes, solar shield, tie-downs, view window and more
- Excluded: shock-mounts, MIL-STD certification

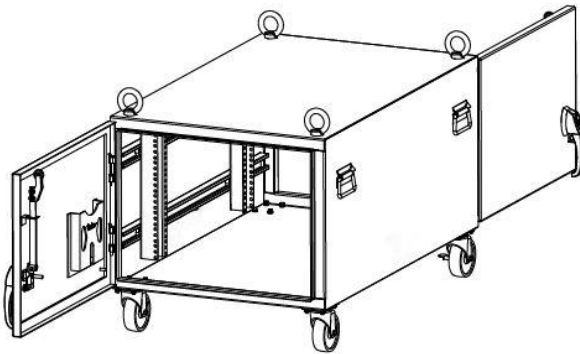

8U Rack-mount Enclosure (Example)

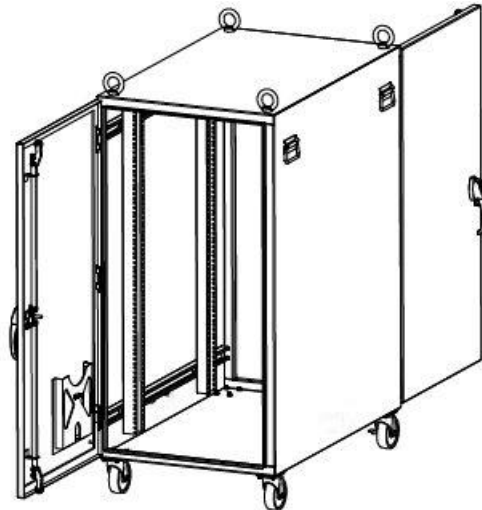

24U Rack-mount Enclosure (Example)